

New version May 2008

You could become an IC designer.

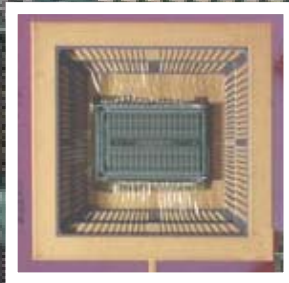

System-on-Chip

If your future career is in:

- Digital circuits and VHDL
- Computer based systems
- Integrated circuits and FPGAs
- Design for low power
- Clockless circuits
- Test and design for test

the **SoC-section at IMM** may be offering the courses relevant to you.

Or you may want to consider the study line "digital systems" within the M.Sc. program in Computer Science and Engineering

Read more inside ...

If you wish to know more, please contact:

Prof. Jens Sparsø email jsp@imm.dtu.dk
Phone: 4525 3747

Prof. Alberto Nannarelli email an@imm.dtu.dk
Phone: 4525 3725

FPGA board for
System-on-chip prototyping

The SoC-sections B.Sc. and M.Sc. Courses:

02154 (5 ECTS, E2A, B.Sc. level) [Approx. 50% of previous course 02151]

Digital Systems Engineering

Design of large digital systems using a structured top-down design process, using VHDL and FPGAs

02155 (5 ECTS, E2B, B.Sc. level) [Approx. 50% of previous course 02151]

Computer Architecture and Engineering

Basic computer architecture – processor organization, pipelining, caches and memory hierarchy. Optimization of software.

02137 (5 ECTS, January, B.Sc. level)

Lab. Course in Digital Systems Engineering

Synthesis of digital circuits and systems from a VHDL-description to and FPGA implementation. Synthesizable VHDL. Internal architecture of an FPGA. Implementation and test of the processor designed in 02151, or some other large circuit.

02204 (5 ECTS, F2A, M.Sc. level)

Design of Asynchronous Circuits

Teaches basic theory and concepts, such that the participants will be able to: (1) design control and data-processing circuits, and (2) read and understand the literature on asynchronous circuit design. Design is at gate level and higher.

02206 (7.5 ECTS, F4A M.Sc. level)

Design of Integrated Circuits

Introduction to the basis of CMOS technology, including design and layout of fundamental digital structures and their interconnect. Includes lab exercises using state-of-the-art CAD tools.

02207 (5 ECTS, E5B, M.Sc. level)

Advanced Digital Design Techniques

Methodologies and techniques for the design of digital systems taking in account a number of constraints such as high-speed and low-power. Synthesis-based design flow targeting standard-cell implementations.

02208 (7.5 ECTS, E4, M.Sc. level)

Test of integrated circuits

Introduction to the methods and concepts in test and design for test, enabling the participants to design integrated circuits of high test quality.

02217 (5 ECTS, F3A, M.Sc. level)

Design of arithmetic processors

Background on computer arithmetic and the basics of implementing in hardware numerical algorithms used in CPUs, graphics (GPU) and other special purpose processors.

Course structure (semesters and prerequisites)

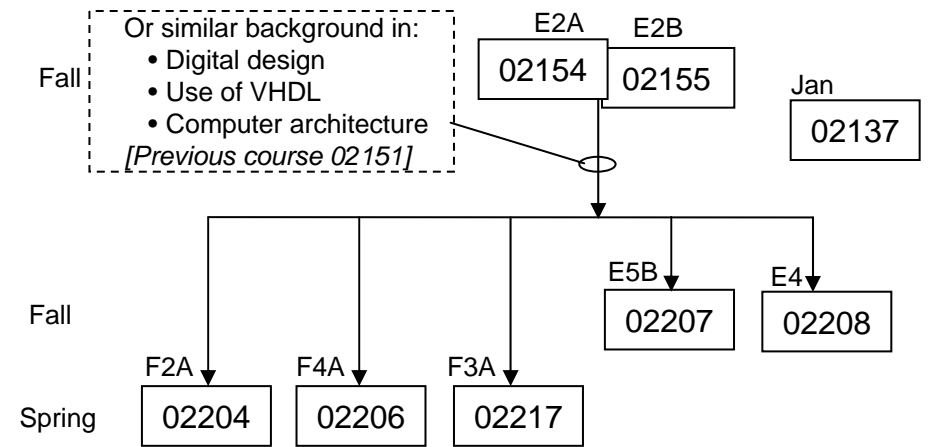

We consider courses 02154, 02155 and 02207 to be core courses which are relevant to students in electrical engineering, communications and computer science and engineering. Courses 02204, 02206, 02208 and 02217 offers these students a range of specialization options. All courses may be taken individually.

M.Sc. in Computer Science and Engineering

Our courses are part of the M.Sc. in Computer Science and Engineering program. The aim of the Computer Science and Engineering program is to educate highly qualified engineers capable of developing complex systems consisting of both hardware and software. The Computer Science and Engineering program contains topics from both the traditional electrical engineering and computer science curricula. The program allow you to specialize into different areas:

- Software Security
- Software Engineering
- Embedded Systems
- Efficient and Intelligent Software
- **Digital Systems**

The **digital systems specialization** addresses electronic systems and devices, typically containing very complex digital hardware. This may be in the form of systems-on-chip (SoC), embedded computer based systems or heterogeneous multiprocessor platforms. These systems form the basis for building intelligent products, i.e. the platforms where hardware and software components are integrated into embedded systems.